

# MK II

## Electric Heat Pump Water Heater

### Product Highlights

- Over 4X more efficient than a standard electric water heater
- Dehumidifies the surrounding area
- Service free
- Long lasting HydraStone™ cement lined tank – no anode rod required
- Quiet application (54 dBA)
- Ducting capabilities available
- 4 run modes
- Side water connections
- Enhanced clearance for easy installation
- Freeze protection
- Heat pump portion can be replaced if needed

Available in 50, 65, 80 and 119 gallons



**Energy Star**  
**5.0 Certified**



**TO LEARN MORE CONTACT**

978-462-6683 | [vaughncorp.com](http://vaughncorp.com)

## The Difference: HydraStone™ Cement Lining

**Cement lined tanks offer significant longevity, trouble-free operation and a lower lifetime cost.**

**Our tanks are lined with a minimum of 1/2 inch high density HydraStone cement – 100 times thicker than glass lining.**

Full coverage is achieved by injecting the precise amount of HydraStone cement into each tank and then centrifugally spun to ensure complete and uniform coverage. This process provides maximum protection from the corrosive effects of hot water. Additionally, cement lined tanks do not require a sacrificial anode, eliminating periodic inspections and replacement costs associated with glass lined tanks.

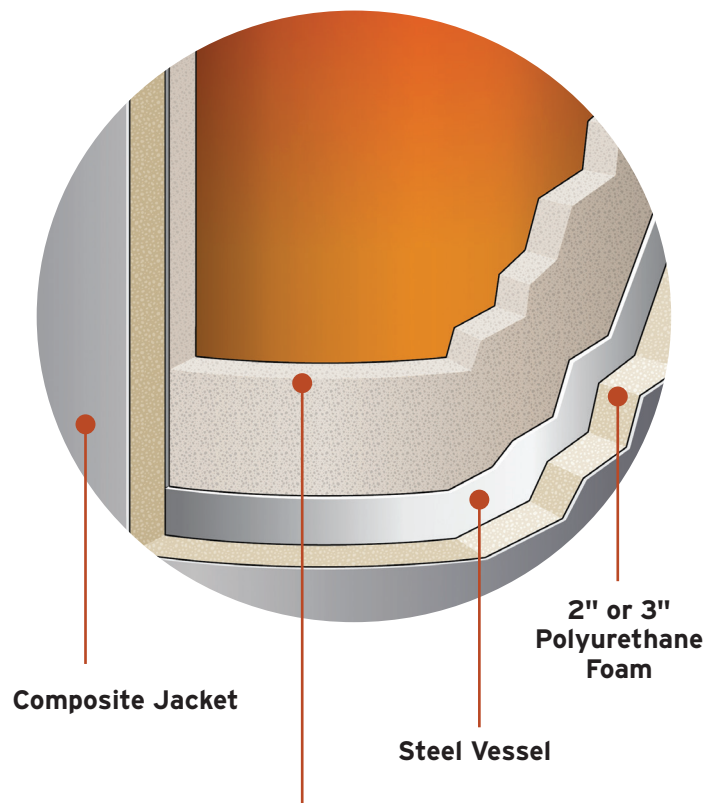

**5/1000 inch glass lining**

**VS**

**1/2 inch HydraStone cement lining**

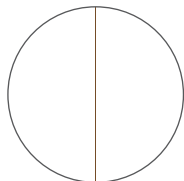

*(actual thickness)*

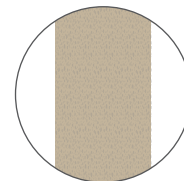

*(actual thickness)*